

## Development of the MyRio Based Mobile Platform

**Jr-Hung Guo\*, Bo-Jun Yang and Kuo-Lan Su**

*Graduate of Electrical Engineering, National Yunlin University of Science & Technology, Yunlin 64002, Taiwan, ROC.  
E-mail: g9710801@yuntech.edu.tw, sukl@yuntech.edu.tw*

**Evgeni Magid**

*Laboratory of Intelligent Robotic Systems (LIRS), Intelligent Robotics Department, Higher Institute for Information Technology and Intelligent Systems, Kazan Federal University, Russia*

### Abstract

The paper develops the MyRio based mobile platform with a robot arm. The structure of the mobile platform uses the Matrix elements. The Matrix elements build the robot arm with four degrees of freedoms, too. The mobile platform integrates some sensors, four DC servomotors, two DC motors, two RC servomotors, a MyRio based control box, and two vision devices. The core controller of the MyRio-1900 control box is the NI-Single-Board RIO 9606 module. The mobile platform embeds a robot arm on the front side. The driver device of the gripper is a RC servomotor. The developed mobile platform uses ultrasonic sensors to detect the obstacles. Trapezoidal acceleration and deceleration algorithm and Proportional-Integral-Derivative (PID) algorithm are used for precise motion control of each DC servomotor. A vision device of the mobile platform can search and recognize the shape and color of the assigned billiard ball. The other recognizes the symbol of each QR code. These vision devices are fixed on the front side of the mobile platform, and recognize the assigned object using Otsu algorithm. In the experimental results, the mobile platform tests the positioning function of the Proportional-Integral-Derivative (PID) algorithm for each DC servomotor. Then we implement the movement precisely of the mobile platform.

*Keywords:* MyRio, DC servomotors, NI-Single-Board RIO 9606 module, Otsu algorithm.

### 1. Introduction

An autonomous mobile platform usually works for a predefined task. The remote user can control the mobile platform doing the assigned task, too. In practice, a human wants the mobile platform to do the assigned task, such as catching an exploder and moving a dangerous object. Many mobile platforms have been widely applied in many fields, too. Such as factory automation, dangerous environment detection, office automation, hospital, entertainment, farm automation and security management system. There are some successful examples, such as ASIMO, PEPPER, NAO, QRIO and AIBO. We have been designed an intelligent mobile robot to do patrol autonomously and auto-recharging process [1,2]. In the paper, we design a mobile platform to finish some assigned tasks with a robot arm using the MyRio control system, and test the fundamental functions on the motion control.

In the past literatures of the robotic research, many experts research stable walking on uneven terrain. Su et al. have designed a mobile robot to solve the problems such that the robots can move from the start point to the target point on uneven terrain. [3]. Peng et al. designed a where/track mobile platform to search and rescue in dangerous environment. The motion modes of the mobile platform can be switched alternatively to adapt on different ground situations [4]. Guo et al developed a mobile platform, based on KNR controller. The mobile robot embed a robot arm with four degrees of freedom, and used of light sensors and touch sensors for line tracking and detects the initial location [5]. Su et al developed a mobile based robot arm using KNRm system. The developed mobile platform uses the vision device to recognize the position of the assigned object, and uses ultrasonic sensors to detect the distance of object and obstacle [6,7].

*© The 2019 International Conference on Artificial Life and Robotics (ICAROB2019), Jan. 10-13, B-Con Plaza, Beppu, Oita, Japan*

The paper is organized as follows: Section II describes the system architecture of the mobile platform and the robot arm, and explains the functions of the MyRio-1900 control box. Section III explains the hardware devices of the mobile platform. Section IV presents the experimental results of the motion control for the mobile platform using PID control method. Section VI presents the brief concluding remarks.

## 2. System Architecture

The system architecture of the mobile platform is shown in Fig. 1. The system contains two parts; one is the laptop and the other is a mobile platform. The laptop can program motion trajectories and recognize color and size of each object using NI LabVIEW software. The monitor interface system is developed on the laptop. The mobile platform contains five parts. There are structure and motors, image system, sensory system, power and drivers and control methods.

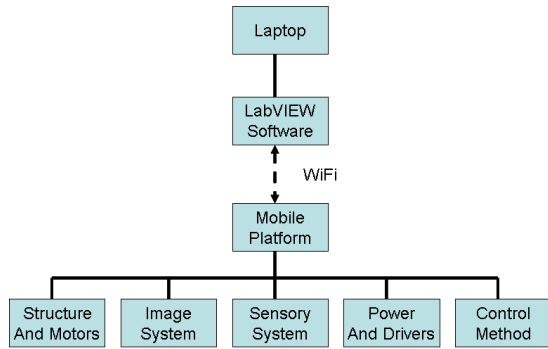

Fig 1. System architecture

The structure of the mobile platform is built by some Tetrax elements. We use three type DC motors to drive the mobile platform with a robot arm. One is four DC servomotors to control the motion trajectories of the mobile platform; two DC motors and two RC servomotors to build the robot arm. The image system uses WSR LifeCam Cinema Video Camera to search the positions of selected billiard balls, and uses Logitech C310 camera to recognize the style of each QR code. The main element of the sensor system is some ultrasonic sensors to be fixed on the frond side of the mobile platform. The ultrasonic sensors can detect the distance from the obstacle.

The main controller of the mobile platform is a MyRio control box to program the control methods. The hardware device of the MyRio-1900 control box is

shown in Fig.2. The length, width and height are about 15cm, 10cm and 3cm. The control box displays the function of each connective pin. Users can select the needed element to connect with the control box for the assigned task. In order to achieve the purpose of accurate positioning, the core controller of the box is Xilinx Zynq-7010 to be a SoC system (a ARM-Cortex-A9 and a FPGA chip). The driver device of each DC servomotor uses the Tetrax DC motor expansion controller.



Fig. 2 MyRio-1900 control box

The control method uses PID control law and trapezoidal acceleration and deceleration algorithm to control each DC servomotor, and tune the mobile platform to follow the programmed trajectories. The controller of the KNRm system computes each compensator signals (P, I and D) according to the error signals as following:

$$e = SP - PV \tag{1}$$

$$u(t) = K_c \left[ e + \frac{1}{T_i} \int_0^t edt + T_d \frac{de}{dt} \right] \tag{2}$$

$SP$  is desired value, and  $PV$  is measured value. The  $e$  is the error value to be the desired value minus the measured value.  $K_c$  is the proportional constant,  $T_i$  is integral time constant, and  $T_d$  is derivative time constant.

## 3. Mobile Platform

The structure integration of the mobile platform uses Matrix element shown in Fig. 3(a). The mobile platform can uses four DC servomotors to connect four mecanum wheels moving on the programmed motion paths. The MyRio system controls each DC servomotor through

the DC servomotor driver is shown in Fig. 3(b), and programs the rotation range according to the feedback signal of the encoder sensor. The controller of the MyRio box uses PID control law and trapezoidal acceleration and deceleration algorithm to control each DC servomotor, and tune the mobile platform to follow the programmed trajectories, and finish the precision position.

The driver elements of the robot arm are two DC motors and two RC servomotors. The robot arm fixes on the front side of the mobile platform, and is driven by the MyRio controller shown in Fig. 4. The structure of the robot arm is built using Tetrix elements. The image system is embedded on the top of the gripper to recognize position and color of the billiard ball, and searches the assigned billiard ball on the competition playground. Then the mobile robot moves approach to the assigned billiard ball, and catches the ball using the gripper of the robot arm, and moves the billiard ball to put down on the assigned position of the QR code.

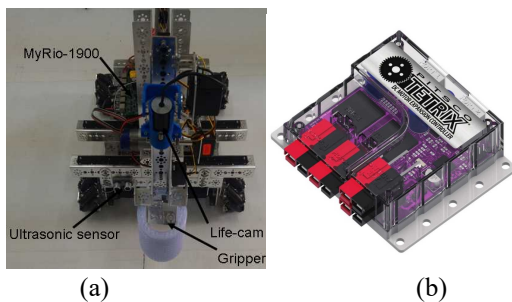

Fig. 3 The mobile platform

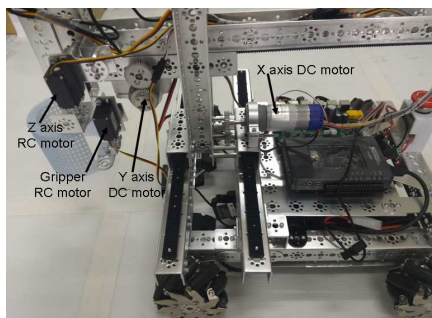

Fig. 4 The robot arm

#### 4. Experimental Results

We implement the experimental results on the competition playground using the mobile platform (length 4m and width 2m). The pre-processing program of the PID control method for each DC servomotor

using LabVIEW software shown in Fig. 5. We set the rotation angle of the DC servomotor to be 180 degree. Then we program the driver software of the DC servomotor using LabVIEW language shown in Fig. 6. In the experimental result, the DC servomotor makes the red label on the top of the wheel shown in Fig. 7(a). Then we run the programmed software to control the wheel turning 180 degree. We can see the label to go down shown in Fig. 7(b).

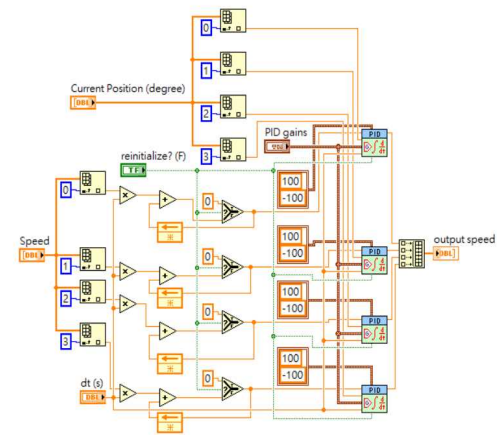

Fig. 5 PID control method program of LabVIEW

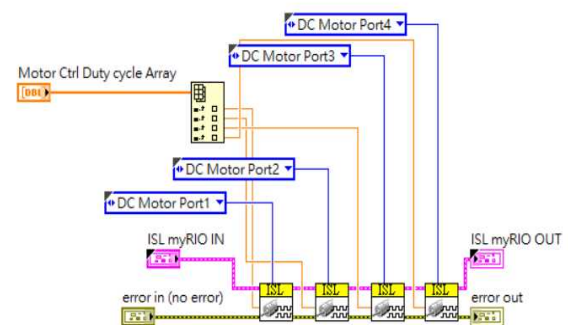

Fig. 6. Driver program of LabVIEW

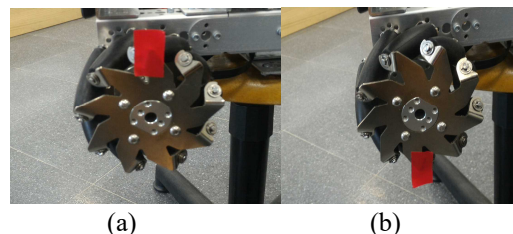

Fig. 7. Experimental result

Then we test the motion precision of the mobile platform, and program the software using the LabVIEW system shown in Fig.8. We set the parameters of the PID Control method  $K_C = 2.0$  ,  $T_i = 0.0$  , and  $T_d = 0.00085$  shown in Fig. 9. Now we implement these parameters to control the mobile platform moving 50cm. We can see the initial position to be zero (the center of the rear wheel) shown in Fig. 10(a). Then the mobile platform moves to stop at the assigned position. We can see the stop position to be about 49.7 cm shown in Fig. 10(b). The speed curve of the mobile platform uses the Trapezoidal acceleration and deceleration algorithm shown in Fig. 11.

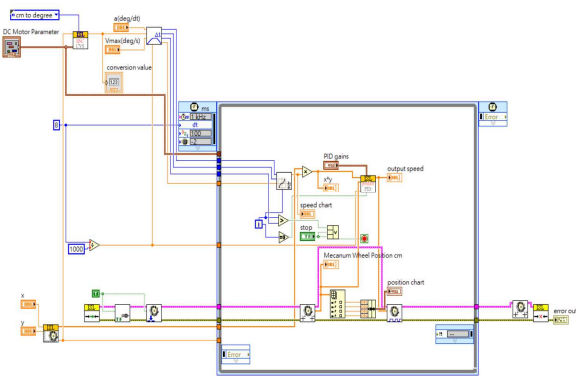

Fig. 8. Motion control program of LabVIEW

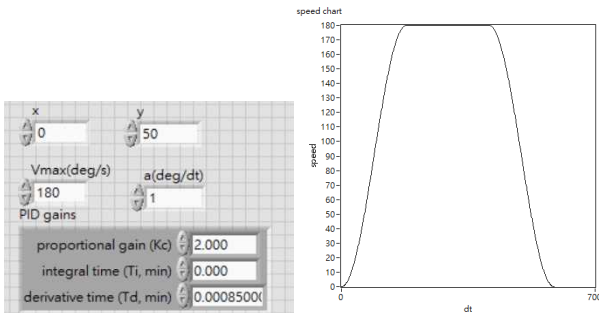

Fig. 9. Parameter values of PID Fig. 11. Speed curve

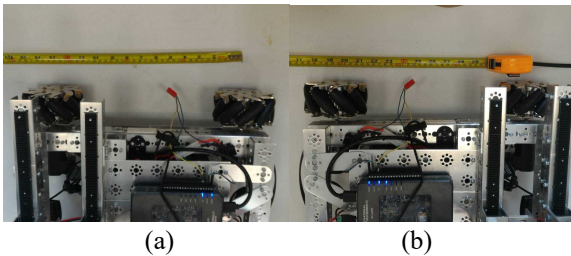

Fig. 10. Experimental result of motion control

## 5. Conclusion

We designed a mobile platform with a robot arm using MyRio-1900 control box, and used the Tetrax elements to construct the mobile platform. The core controller of the MyRio box programs trapezoidal acceleration and deceleration algorithm and PID algorithm to control each DC servomotor of the mobile platform. The platform used two vision devices. One is WSR LifeCam Cinema Video Camera; the other is Logitech C310 camera. In the experimental results, the mobile platform can finished the precision position of each DC servomotor, and moved to the assigned distance very successfully. In future, they will finish various tasks with the image recognition function.

## Acknowledgment

This work was supported by the Ministry of Science and Technology of Taiwan (MOST 107-2221-E- 224-053).

## References

1. K. L. Su, Y. L. Liao, J. H. Guo and C. Y. Chung, Implement of the Auto-docking Processing for Mobile Robots, *The Innovative Computing, Information and Control – Express Letters (ICIC-EL)*, Vol.5, No.1, pp.31-36, 2014.
2. S. H. Chia, J. H. Guo, K. L. Su and B. Y. Li, Team Mobile Robots Based Intelligent Security System, *Applied Mathematics & Information Science*, Vol.7, No.2L, pp.435-440, 2013.
3. S. T. Su, C. H. Chen and K. L. Su, “Develop a Mobile Robot Moving on Uneven Terrain,” *The Innovative Computing, Information and Control – Express Letters , Part B, (ICIC-ELB)*, Vol.6, No.2, 2015, pp.459-464
4. A. Peng, Y. Zhou, J. Hu and Y. Ou, “Mechanical design for wheel/track transform mobile platform-search and rescue robot,” *IEEE Internation Conference on Robotics and Biomimetics*. P.1787, 2014
5. J. H. Guo, K. H. Hsia, K. L. Su and J. T. Wang, Development of the Mobile Robot With a Robot Arm, *International Conference on Industrial Technology(ICIT)*, Taipei, Taiwan, March 14-17, pp.1648-1653, 2016.
6. J. H. Li, K. H. Hsia, J. H. Guo and K. L. Su, “Development of the KNRm System Based Mobile Robot,” *The Innovative Computing, Information and Control – Express Letters, Part B, (ICIC-ELB)*, Vol.9, No.3, 2018, pp.185-194.
7. J. H. Li, J. H. Guo and K. L. Su, “Implementation of the Mobile Based Robot Arm for Image Recognition,” *International Conference on Artificial Life and Robotics*, Beppu, Oita, Japan, Feb. 1-4, 2018, pp.58.