

Max Talanov<sup>1</sup>, Evgenii Zykov<sup>1</sup>, Igor Lavrov<sup>2</sup>, Victor Erokhin<sup>3</sup>

<sup>1</sup>Kazan Federal University, Kazan, Russia; <sup>2</sup>Mayo Clinic, Rochester, USA; <sup>3</sup>Institute of Materials for Electronics and Magnetism, Italian National Council of Research, Parma, Italy

## 1. Introduction

There were several models of biological neuron developed so far for different purposes, starting from McCulloch and Pitts that is currently widely used in artificial intelligence applications, Izhikevich and Hodgkin-Huxley models. The interest to new models of biological neuron is increased by huge projects: the Human Brain Project, Blue Brain Project and the BRAIN initiative as well as the exponential interest to almost all spheres of the artificial intelligence.

## 2. Experimental design

In this position paper we introduce high-level design schematic and block diagram of a memristive electronic neuron that is capable of three types of STDP learning: excitatory: Hebbian or 1/x, inhibitory: "sombbrero" and sinusoidal-like function. The proposed schematic is also capable of neuromodulation via dopamine D1 receptor that modulates the amplitude of learning feedback. The proposed high-level block diagram of a memristive neuron device is designed to be used in neuromorphic prosthesis devices in invasive and non-invasive manner, as well as exoskeletons and robotic devices.

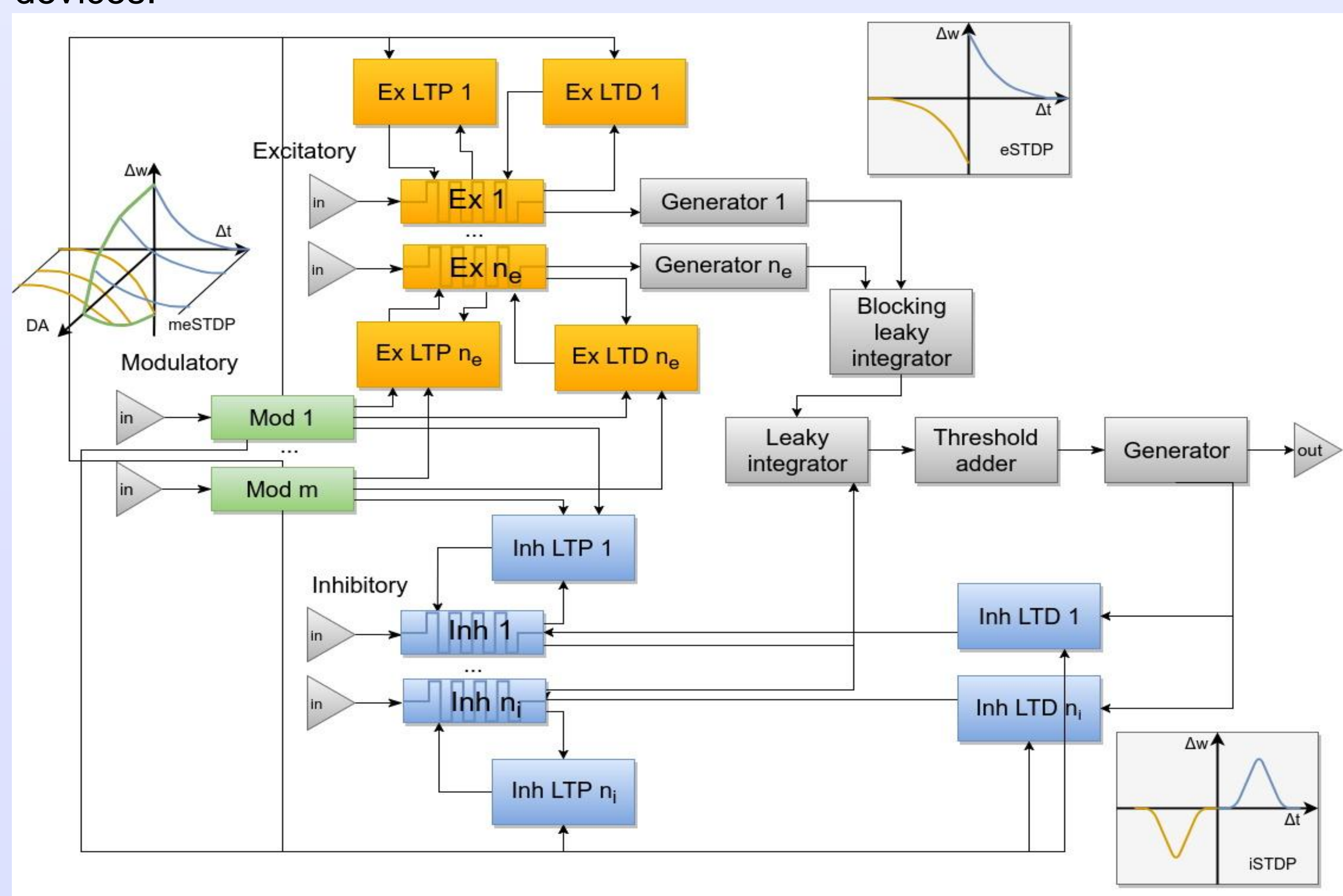

Fig. 1. The block diagram of memristive artificial neuron

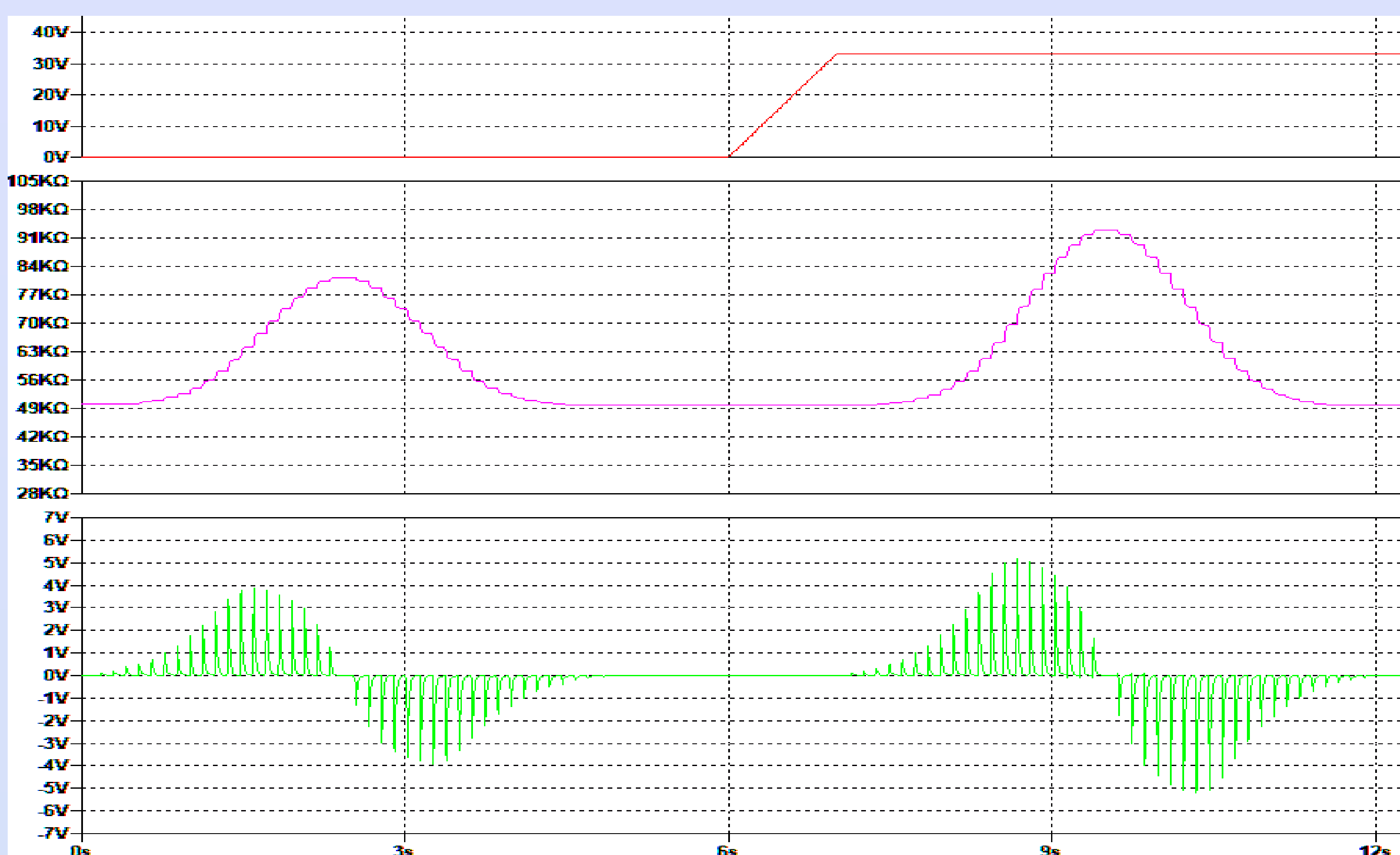

Fig. 2. The simulation results of learning (STDP): top – level of DA influence or setup of DA potentiometer, middle – graph of memristive device conductivity, bottom– learning impulses (STDP).

## 3. Results

The modelling results are presented in form of simulation of electronic schematic via LTSpice tool as well as physical prototyping of parts of a schematic. We demonstrate the results of modelling and validation that plays important role to indicate an option of a memristive device to be integrated with biological nervous system. For validation purposes we run the series of experiments to test the functionality and demonstrate the bio-signals compatibility taking in account the timing parameters and dynamics of spikes.

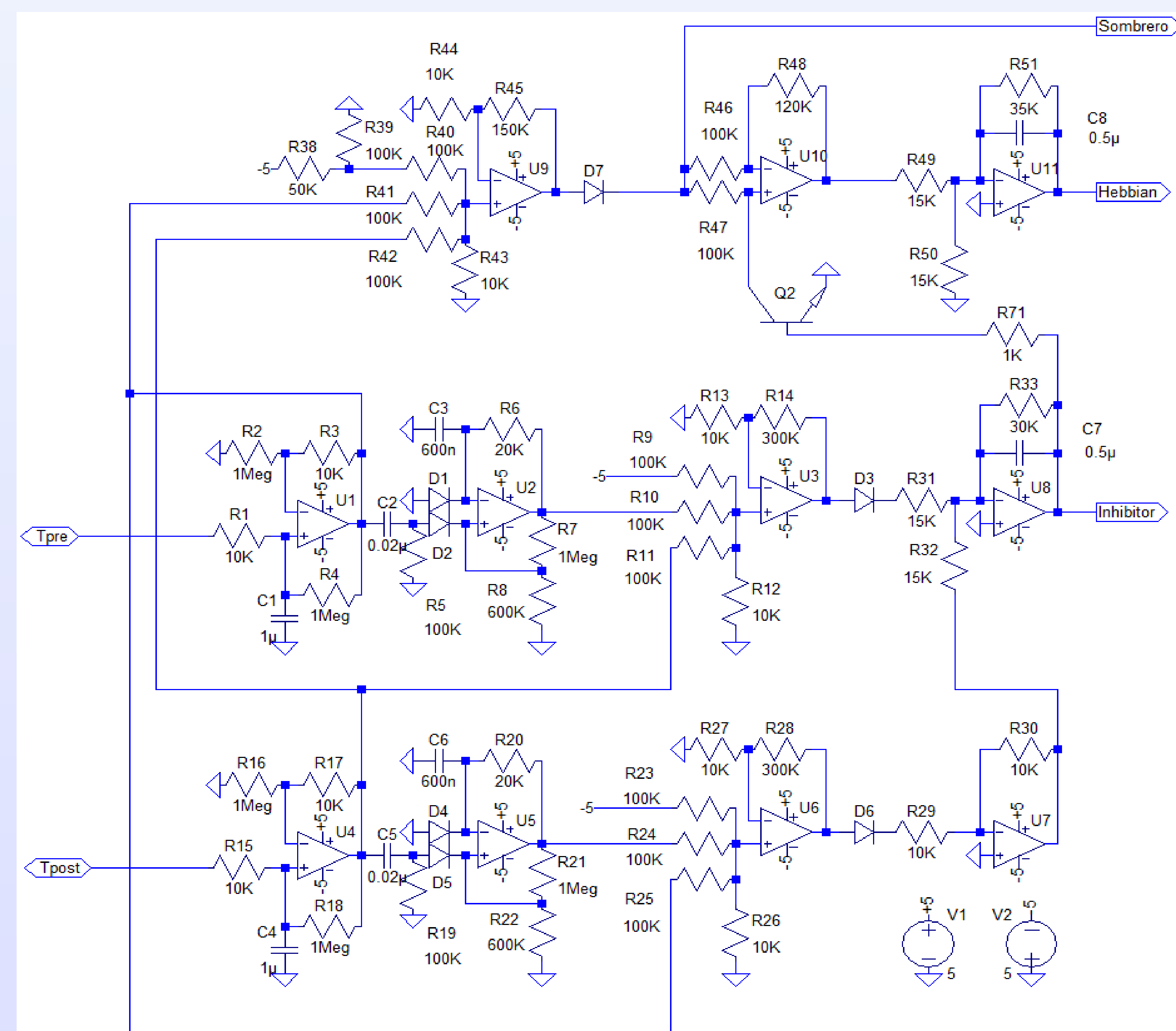

Fig. 3. Wiring schematic of modulatory, excitatory and inhibitory memristive neuron device.

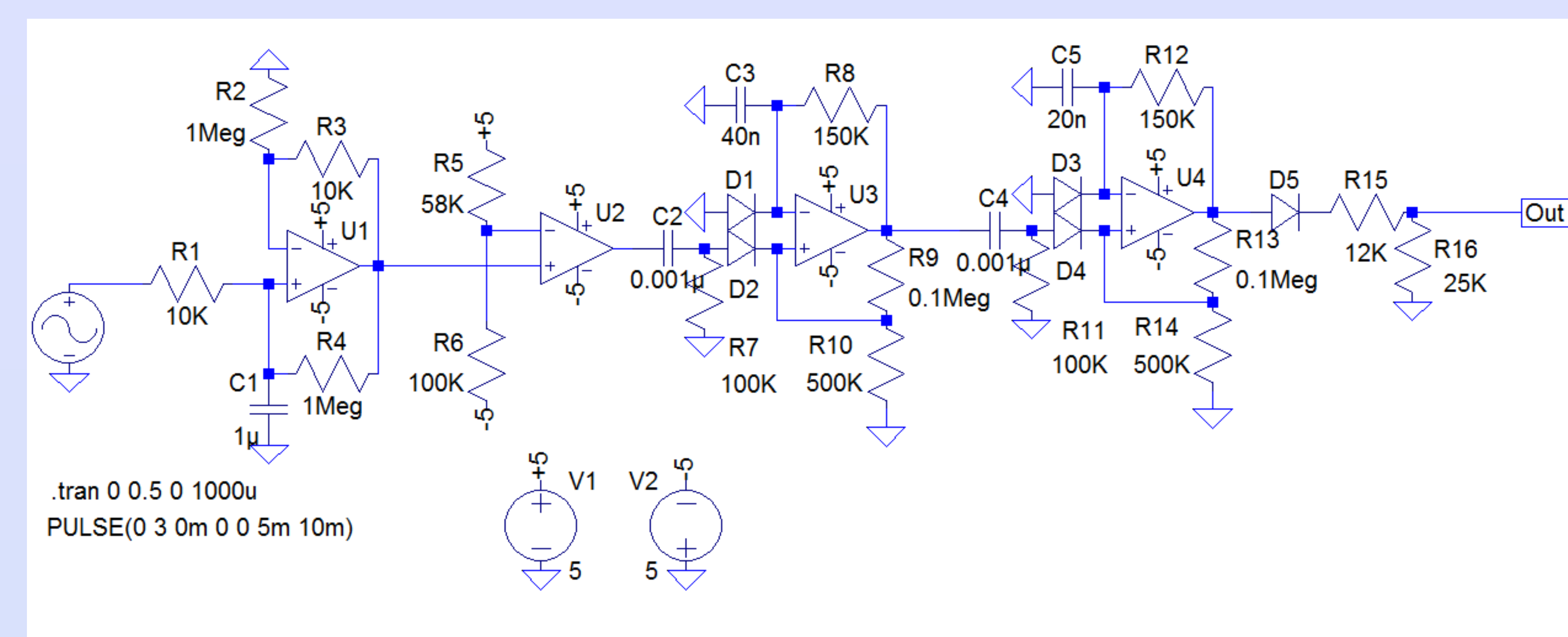

Fig. 4. Wiring schematic of leak-generatot

## 4. Conclusion

In this position paper we propose novel architecture of bio-plausible memristive neuron that is capable of inhibition and neuromodulation via D1 dopamine receptor. We demonstrate results of validation of the model via simulation with the comparison with biological neurons spiking activity. We plan to use the results of the current project during the electronic implementation of a memristive reflex arc that could be used as neuromorphic prosthesis for artificial or natural limbs.

Correspondence: max.talanov@gmail.com