

Investigation of the spatial coherence of an extended light source

Experiment Objective: Investigation of the coherence condition for extended light sources through the example of a spectral lamp.

Optical elements and apparatus:

- ✓ 1 Spectral lamp Hg 100, pin contact;
- ✓ 1 Housing for spectrum lamps w. pin socket
- ✓ 1 Universal choke, in housing, 230 V, 50 Hz
- ✓ 1 Optical bench, 1 m, standard cross section
- ✓ 2 Optics riders 60/34
- ✓ 1 Optics rider 60/50
- ✓ 3 Optics riders 90/50
- ✓ 1 Monochromat. light filter, yellow/green
- ✓ 1 Diaphragm with 4 double slits
- ✓ 2 Holders with spring clips
- ✓ 2 Sliding diaphragm
- ✓ 1 Adjustable slit
- ✓ 1 Lens in holder, $f = + 50$ mm
- ✓ 1 Ocular with scale



Fig.1. Experimental setup

Basic Information

Coherence is the capacity of different waves to elicit stationary interference. A temporally static interference structure can then only be observed if the phase difference of any partial wave at two different places is of less than 2π . The partial waves are then called spatially coherent.

The spatial coherence of a light source can be studied with the double-slit experiment, in which a light source illuminates a double slit, with slits of width b and a gap of length g between the slits. If the beamlets emitted from the light source are coherent at the two slits, then an interference pattern can be observed behind the double slit.

For a broad light source of width a the beamlets that come from the source's edges and overlap at the outer edges of the slits have the greatest path length difference and also the greatest possible phase difference. The difference in path lengths here is:

$$\Delta S = a \cdot \sin \alpha \approx a \frac{\frac{1}{2}(g+b)}{L} \quad \text{for } L \gg a, b, g.$$

If the difference in path lengths is smaller than $\frac{\lambda}{2}$, then the maximum phase difference possible between the two slits is smaller than 2π , and the illumination is coherent.

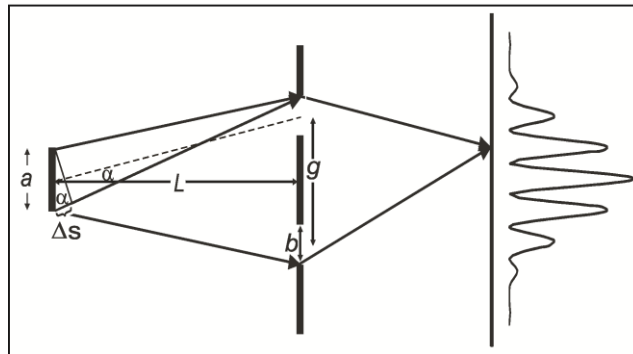

Fig.2. Double-slit experiment

The condition for a coherent illumination of the two slits is:

$$\Delta S = a \cdot \sin \alpha = \frac{1}{2} \frac{a}{L} (g + b) < \frac{\lambda}{2}$$

To produce an interference pattern, the farther away the light source is, the bigger it may be.

The experiment investigates this coherence condition. An adjustable single slit illuminated by an Hg spectral lamp serves as the light source. With an appropriate filter we have a monochromatic light source with variable width a . At a distance L from the single slit, double slits with different gaps g between the slits (and a fixed width b) are illuminated. The adjustable single slit's width a is determined for each gap g , such that the interference pattern behind the double slit becomes fuzzy, i.e. the coherence condition is no longer fulfilled.

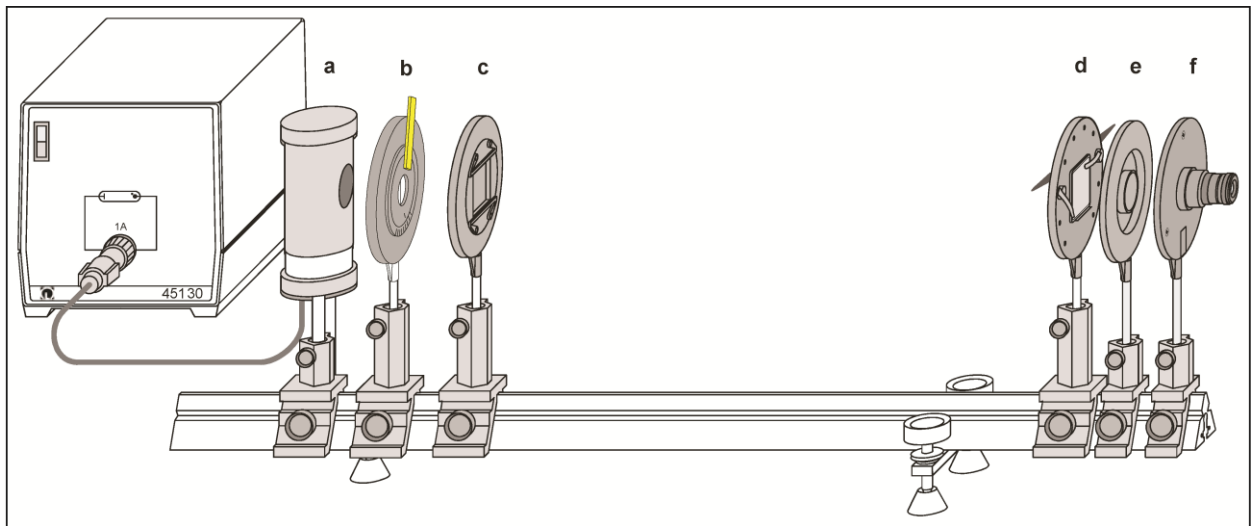

Fig.3. Setup of the double-slit experiment. (a) Spectral lamp Hg 100, pin contact; (b) Adjustable slit; (c) Monochromatic light filter, yellow/green; (d) Double slit; (e) Lens, $f = +50$ mm; (f) Ocular with scale.

Setup

Note: Conduct the measurements in a room that is made as dark as possible.

The experiment's setup is represented in Fig 2. The assembly requires the following steps:

- Attach the spectral lamp Hg 100 (a) in the optics rider 60/50 to one end of the optical bench.
- Mount the adjustable slit (b) about 5 cm behind the spectral lamp.
- Arrange the spectral lamp (a) so that the adjustable slit (b) is illuminated in its center.
- Lock the monochromatic light filter, yellow/green (c), in the holder with spring clips and mount it on the optical bench behind the adjustable slit (b).
- Lock the diaphragm with 4 double slits (d) in the holder with spring clips and mount it on the optical bench about 50 cm behind the adjustable slit (b). Additionally, fasten the sliding diaphragm in the holder with spring clips such that it can be aligned with the double slits' illumination.
- Orient the double slits (d) and the adjustable slit (b) so that they are parallel to each other. Make sure that the holders stand perpendicular to the optical axis, as otherwise the nominal values for the slit width or gap between slits would not correspond to the values implemented in the experiment.
- Position the lens in holder with $f = 50$ mm (e) in the optics rider 60/34 directly behind the diaphragm with 4 double slits (d).
- Mount the ocular with scale (f) in the optics rider 60/34 directly behind the lens with $f = 50$ mm (e).
- Attach the universal choke to the spectral lamp and switch it on; wait a few minutes as it warms up.

Procedure:

- Arrange the double slit with a slit interval $g = 0.25$ mm and a web thickness $b = 0.20$ mm centered on the optical axis. Set the sliding diaphragms so that the other double slits are not illuminated.
- Set the adjustable slit (b) to a width of $a = 0.10$ mm.
- Adjust the lens (e) and ocular (f) to the double slit so that the double slit's interference pattern is pictured very distinctly.
- Slowly increase the slit width a until the borders of the interference pattern become fuzzy, and make a note of this width.
- Repeat the experiment with the other double slits.

Analysis and Discussion

For all double slits, the adjustable slit's width a at which the interference pattern just became fuzzy was determined in the measurement. The distance L between the adjustable slit and the double slit was $L = 45$ cm. The data is summarized in Table 1. To check the coherence condition, the values were inserted into the inequality

$$\frac{1}{2} \frac{a}{L} (g + b) < \frac{\lambda}{2} \quad \text{or} \quad \frac{a}{L} (g + b) < \lambda$$

and the results likewise recorded in Table 1.

Table 1: Measured data and results

Double slit		Adjustable slit	Coherence condition
Slit interval g (mm)	Slit width b (mm)	Slit width a (mm)	$\frac{a}{L} (g + b)$ (nm)
0.25	0.20	0.6	600
0.50	0.20	0.4	622
0.75	0.20	0.3	633
1.00	0.20	0.25	667

For all slit widths, insertion into the coherence condition's equation produces values greater than the studied wavelength $\lambda = 546$ nm. So the coherence condition is no longer fulfilled right at the values for g , b , a and L used in each case.

The comparison between the different values for the double slits' gap g and the diameter a of the light source (here the adjustable slit) shows that, for a fixed distance L , the farther away the two places (here the double slits) are from each other, the smaller the diameter a must be for the light to still be coherent.

Alternatively, the distance L can also be changed. For very large light sources, only the distance L must therefore be big enough to still observe an interference pattern behind the double slit. Therefore, stars can also produce an interference pattern, since there is an even greater distance given. For example, the nearest

fixed star Proxima Centauri has a diameter $a \approx 10^{10}$ m and a distance $L \approx 4 \cdot 10^{16}$ m. For $\lambda = 500$ nm, we get from the coherence condition $g+b = 2$ m.

As the wavelength λ increases, maintaining the coherence condition also becomes easier. This is among other things the basis for radio astronomy.

Note:

The spatial coherence's dependence on the light source's size and distance is also used to gauge the diameter of stars (Michelson's stellar interferometer): the light coming from the star falls on a double slit with variable interval (usually implemented by two mobile mirrors) and overlaps again behind the slit. If the star's distance from the Earth is known, then its radius can be determined with the coherence condition from the smallest gap between slits at which the interference pattern becomes fuzzy. Depending on the star's size and distance, the gap between the slits can measure several meters.