

PAPER • OPEN ACCESS

The Swimming Behavior of Daphnia Magna Ensemble in Two-Dimensional Space from the Diffusion Motion Point of View

To cite this article: E I Nasyrova and O V Nikitin 2020 *IOP Conf. Ser.: Earth Environ. Sci.* **459** 042027

View the [article online](#) for updates and enhancements.

The Swimming Behavior of *Daphnia Magna* Ensemble in Two-Dimensional Space from the Diffusion Motion Point of View

E I Nasyrova¹, O V Nikitin¹

¹Institute of Environmental Sciences, Kazan Federal University, Kremlevskaya str., 18, Kazan, 420008, Russia

E-mail: oleg.nikitin@kpfu.ru

Abstract. Locomotion and dispersal are important processes that affect the distribution and abundance of organisms in aquatic environment. In this study we observed the movement of a group of *Daphnia magna* called an ensemble. In laboratory conditions, the distribution of fifty daphnids (in triplicate) at the release from the point source in two-dimensions was examined. In experiments, animals were placed in a square plastic container with thin layer of culture medium and the video of their movements was recorded. Video processing and measuring of swimming behaviour was carried out by the TrackTox software. Mathematical and statistical analyses were performed using the functions and packages of the R software. The diffusion motion equation used allowed to obtain the value of the diffusion coefficient, which in our case was $0.051 \pm 0.009 \text{ cm}^2 \text{ s}^{-1}$. The approach used can be used to model the migration and spatial distribution of these microscopic crustaceans. Moreover, given the fact that certain parameters of swimming behavior are already used to toxicity assessment, the diffusion parameters of a *Daphnia* ensemble can also be proposed as a characteristic in ecotoxicological studies.

1. Introduction

The genus *Daphnia* (Crustacea: Cladocera) is widely distributed in a variety of freshwater ecosystems. This group of microscopic crustaceans plays an important role in the trophic relations, as an important consumer of primary phytoplankton production, as well as creator of secondary production for the subsequent levels of consumers [1], [2], [3].

Among the many species of the genus, reference on the species *Daphnia magna* Straus, 1820 is the most common in the literature. The species is widely used for ecological (including food webs, predator-prey interactions, parasitism), evolutionary and physiological studies, it is also an important model for toxicological studies [1], [2], [4], [5].

The biology and ecology of *Daphnia* is dependent on a number of biotic and abiotic factors. One of the ways *Daphnia* adapts to changes in environmental conditions is their swimming behavior. Individual *Daphnia* behaviour shows extreme plasticity as a response to both external and internal factors, such as temperature, light, individual size, food, presence of predator infochemicals and occurrence of toxic substances [2], [6], [7], [8], [9], [10], [11], [12], [13]. *Daphnia* swimming behaviour is complex and multiparametric. In the literature there is a wide range of characteristics that describe it: swimming time, swimming speed, behavioural strength, hopping frequency, horizontal and vertical distribution, distance travelled, swimming trajectory, turning angle and other [13]. All of them



based on the features of the swimming behavior of these animals. *Daphnia* has a characteristic swimming style called "hop-and-sink". In addition, *Daphnia* swim with frequent deviations to the left and right of the straight course. Such a zig-zag path of movement allows to consider the trajectory as a fractal structure [14].

Daphnia are not social animals. Individual animals are observed to swim alone with no apparent distress [15]. Although periodically their behavior is found the phenomenon of swarming. Swarming is a collective behavioural response leading to vortex formation [16]. This type of reaction occurs normally in daphnids responding to light change, food presence or predator pressure [3], [13].

To describe the model of swimming behavior of *Daphnia* use different approaches, for example models using Active Brownian particles [17], methods based on Random walk theory and those based on continuous stochastic differential equations [15]. The locomotory studies traditionally categorize an animal's control of its movement into angular regulation (i.e. klinokinesis) and velocity regulation (i.e. orthokinesis) [18]. Locomotion and dispersal are important processes that affect the distribution and abundance of organisms. Organisms swimming at a characteristic speed U and reorienting at a characteristic time T are expected to disperse with an effective diffusion constant in the order of U^2/T [19].

The aim of this work is to characterize the behavior parameters of a *Daphnia* ensemble in a two-dimensional space from the diffusion motion point of view

2. Material and methods

2.1. Experimental animals

The experiments were performed with parthenogenetically reproducing laboratory clones of *Daphnia magna* Straus cultivated for several years in the Department of Applied Ecology at the Kazan Federal University (Kazan, Russia). The bulk culture was maintained at constant conditions of temperature (20 ± 1 °C), under luminescent cool white light (500–1000 lux) and 16:8 h light/dark cycle in a laboratory incubator V4 (Energolab, Moscow, Russia). The culture medium (aged tap water) was changed every other day, and neonates were removed within 24 h. Daphnids were fed daily with 1–2 mL *Chlorella vulgaris* Beijerinck suspension. For experiments adult female *D. magna* individuals of 1.76–2.43 mm size were used. Size measurements of animals were performed using an ocular micrometer.

2.2. Diffusion motion simulation and swimming behaviour measurement

To simulate the diffuse motion of *Daphnia*, the equipment presented in figure 2 was used. The main elements of the equipment are a square plastic container (35x25 cm) for testing, a height-adjustable retort stand with a LED illuminator and a camera.

A thin layer of culture medium was poured into the container (to form a depth of 2 cm). Then a round plastic tube open on both sides with a diameter of 2.5 cm was placed in the center of the container. It performed as an enclosure for the distribution of *Daphnia* before the start of the experiment.

At the beginning of the experiment, fifty animals were placed inside the tube. Further the bounding tube was raised and daphnids could be freely distributed beyond. Within 60 seconds after the start of the experiment the *Daphnia* location was recorded by the camera (25 frames s^{-1}). The experiment was performed in triplicate (the total number of *Daphnia* were 150 individuals).

Video processing and measuring of swimming behaviour was carried out by the TrackTox software [12]. Horizontal two-dimensional coordinates of daphnids and the density of animals at different distances from the initial aggregation point were determined for diffusion motion simulation.

In addition, separate experiments were performed to measure (as described in [20]) the vertical swimming speed of daphnids.

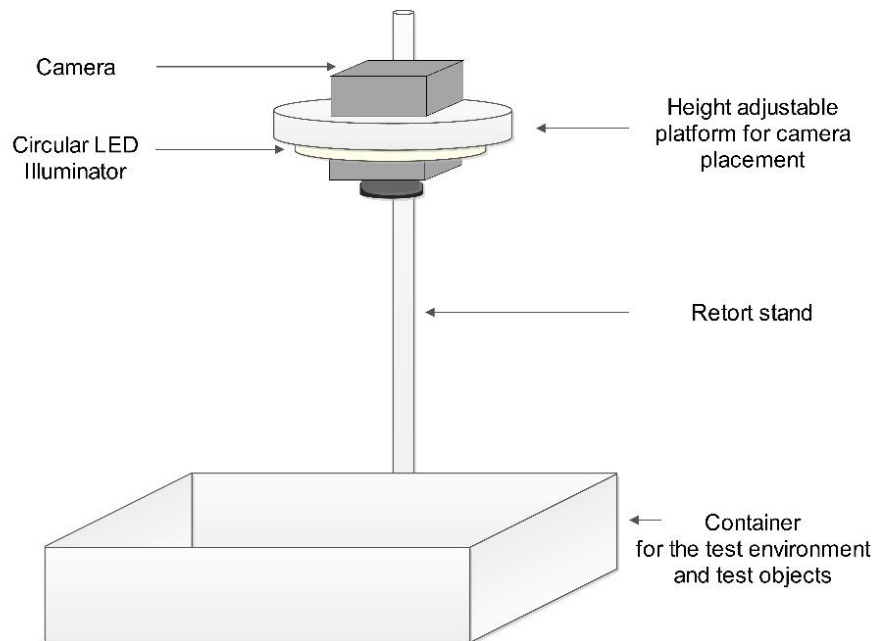

Figure 1. Equipment for studying the parameters of the behavior of the Daphnia ensemble in two-dimensional space from the point of view of diffusion motion.

2.3. Mathematical and statistical analyses

All mathematical and statistical analyses were performed using the functions and packages of the R software [21].

3. Results and discussion

3.1. Equation of the Daphnia diffusion motion

Observations of the distribution of the Daphnia ensemble show that their movement is similar to random walk of the particles in a stationary medium. In the first approximation the distribution of Daphnia ensemble can be described as diffusion.

The experiment in the container was carried out in a shallow water layer, when the movement of daphnia was mainly in the horizontal direction. Moreover, three-dimensional tracking of Daphnia indicate that they normally swim in approximately two-dimensional planes (± 2 cm) [15]. Therefore, a two-dimensional mathematical model of the diffusion transport of daphnids can be used.

Consider the distribution of Daphnia from an instantaneous point source in a stationary fluid ($U_x = U_y = U_z = 0$). The flow conditions are uniform in z ($\partial/\partial z = 0$). Let the instantaneous release of N daphnids occurs at $x = y = 0$ in the point between two planes with a height L_z (figure 2). The mass of daphnids is initially distributed uniformly in z and with negligible dimension in y and x , such that the initial concentration is $C(x, y, T = 0)$,

$$C(x, y, T = 0) = M\delta(x)\delta(y) \quad (1)$$

where $\delta()$ is the Dirac delta function [22].

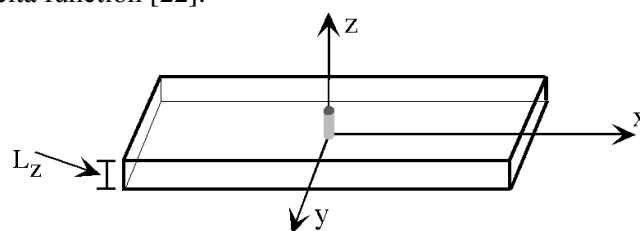

Figure 2. Space for modeling diffusive motion.

Away from the point source of Daphnia are absent:

$$\begin{aligned} C(x, y, T) &= 0, x \rightarrow \infty \\ C(x, y, T) &= 0, y \rightarrow \infty \end{aligned} \quad (2)$$

For generality, we will assume anisotropic diffusion, ($D_x \neq D_y$). The transport equation for this system is then,

$$\frac{\partial C}{\partial T} = D_x \frac{\partial^2 C}{\partial x^2} + D_y \frac{\partial^2 C}{\partial y^2} \quad (3)$$

From Fick's Law and by inspection of (3), the diffusion in x depends only on the distribution in x and the diffusion in y depends only on the distribution in y .

Thus, a solution for $C(x, y, T)$ can be found as,

$$C(x, y, T) = \frac{M}{L_z 4\pi T \sqrt{D_x D_y}} \exp\left(-\frac{x^2}{4D_x T} - \frac{y^2}{4D_y T}\right) \quad (4)$$

where C is the concentration of Daphnia, in individuals per cm^2 ; D is the diffusion coefficient or diffusivity, in $\text{m}^2 \text{s}^{-1}$; L_z is the height of distribution of Daphnia along z ; M is the mass of the Daphnia ensemble, in individuals.

In two dimensions, the square of the distance from the origin to the point (x, y) is [23],

$$R^2 = x^2 + y^2 \quad (5)$$

therefore,

$$C(r, t) = \frac{M}{L_z 4\pi T D} \exp\left(-\frac{R^2}{4DT}\right) \quad (6)$$

For the presented solution of the diffusion equation for the instantaneous point source in the two-dimensional case, the maximum concentration is retained at the point of emission. The corresponding value of $C_{max}(t)$ can be calculated by the formula,

$$C_{max} = \frac{M}{L_z 4\pi T D} \quad (7)$$

where C_{max} is the maximum concentration of objects near the release point, daphnids per cm^2 .

From (7) it is possible to obtain a formula for the diffusion coefficient,

$$D = \frac{M}{L_z 4\pi T C_{max}} \quad (8)$$

Thus, to find the diffusion coefficient, in the experiment it is necessary to measure the concentration of Daphnia in the release area at different points in time.

3.2. Diffusion movement of Daphnia

Three replications were performed. After 60 seconds, the ensemble Daphnia reached a radius of ≈ 10.25 cm. We divided this radius into 10 parts with a step of 1 cm (from 1.25 cm) and determined the number of daphnids in each circle. The diffusion coefficient was calculated for the area with the maximum concentration ($r = 1.25$ cm; table 1).

Table 1. Parameters of Daphnia diffusion movement.

Repl.	Parameters of Daphnia movement	Time (T), s			
		15	30	45	60
1)	Number of Daphnia (N_{1max}), pcs	12	7	5	3
	Concentration (C_{1max}), pcs cm^{-2}	2.4	1.4	1.0	0.6
	Diffusion coefficient (D_{1max}), $\text{cm}^2 \text{s}^{-1}$	0.054	0.047	0.043	0.054
2)	Number of Daphnia (N_{2max}), pcs	11	7	5	4
	Concentration (C_{2max}), pcs cm^{-2}	2.2	1.4	1.0	0.8
	Diffusion coefficient (D_{1max}), $\text{cm}^2 \text{s}^{-1}$	0.059	0.047	0.043	0.041
3)	Number of Daphnia (N_{3max}), pcs	9	6	4	4
	Concentration (C_{3max}), pcs cm^{-2}	1.8	1.2	0.8	0.8
	Diffusion coefficient (D_{3max}), $\text{cm}^2 \text{s}^{-1}$	0.072	0.054	0.054	0.041

An experiment with simulating the diffusion movement of daphnia confirmed the assumption that the movement of the Daphnia ensemble is similar to Random walk suspended particles in a stationary fluid (figure 3).



Figure 3. The initial (left) and final (right) observation position of the Daphnia ensemble in the experiment chamber.

Figure 4 shows the distribution density of Daphnia from the aggregation point at different time intervals. It can be seen that the concentration of Daphnia decreases with time and becomes almost uniform over the entire area of the container.

In accordance with equation (8) and the calculations made (table 1), the diffusion coefficient for the Daphnia ensemble was $0.051 \pm 0.009 \text{ cm}^2 \text{ s}^{-1}$ (mean \pm SD). The data obtained are close to the ones on the diffusion coefficient of daphnia, found by Garcia – $0.0217 \text{ mm}^2 \text{ s}^{-1}$ [15]. Thus in a time of 60 s in two dimensions the typical Daphnia would diffuse a distance of $r = (4DT)^{1/2} \approx 3.5 \text{ cm}$. In a total time of 8 h (daytime) the agent would diffuse about 0.77 m.

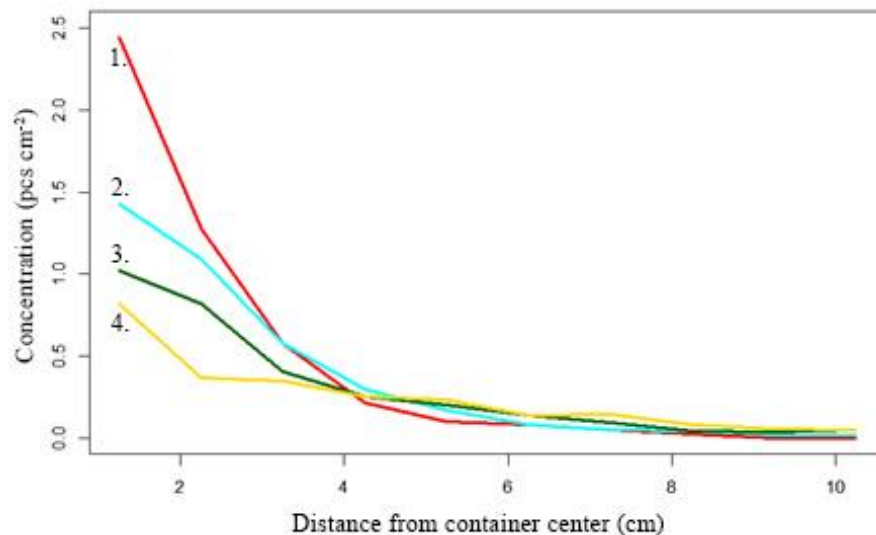

Figure 4. Daphnia distribution density from the aggregation point. The lines correspond to the time of Daphnia measurement: 1) – 15 seconds, 2) – 30 seconds, 3) – 45 seconds, and 4) – 60 seconds.

The distribution of Daphnia depends on the swimming speed, which in turn depends on many external factors. For example, in the absence of light, it is less than when it is present [24]. Swimming speed also depends on Daphnia size, food availability [10].

We analyzed the Daphnia swimming speed of depending on the size (Figure 5). Within the limits of the considered sizes of animals (1.76–2.43 mm, mean is 0.31 cm s^{-1}) a weak but significant correlation between these parameters was found (Pearson correlation $r = 0.22$, $p \ll 0.001$).

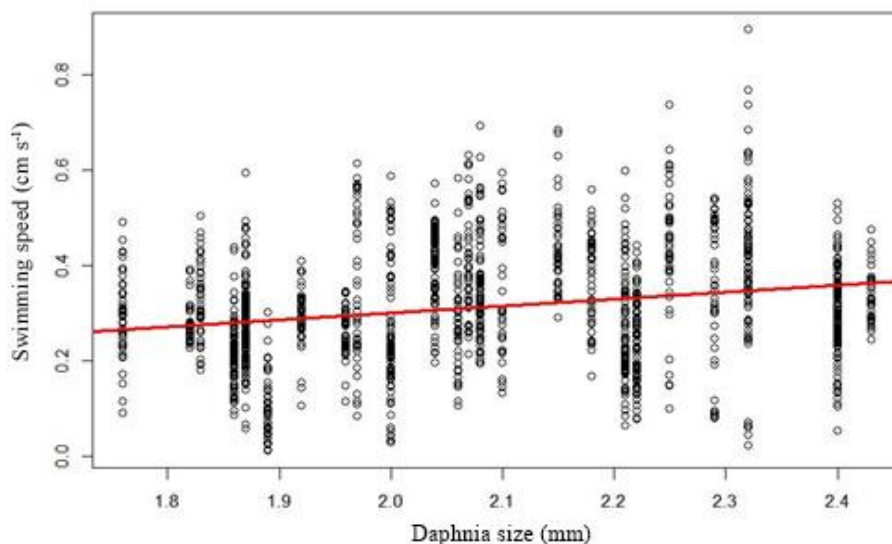

Figure 5. Vertical swimming speed of Daphnia, depending on the size of individuals.

The effect of Daphnia size on swimming speed is weak, but we cannot ignore this factor. In this regard, for experiments it is necessary to use daphnids similar in size.

4. Conclusion

In this study in a controlled laboratory environment, we observed the movement not of several separate daphnids, but the distribution of a group of animals. The diffusion movement equation used allowed us to obtain the value of the diffusion coefficient, which in our case was $0.051 \pm 0.009 \text{ cm}^2 \text{ s}^{-1}$. The approach used can be used to model the migration and spatial distribution of these microscopic crustaceans. Moreover, given the fact that certain parameters of swimming behavior are already used to toxicity assessment [12], [13], [25], the diffusion parameters of a Daphnia ensemble can also be proposed as a characteristic in ecotoxicological studies.

5. References

- [1] Ebert D 2005 *Ecology, Epidemiology, and Evolution of Parasitism in Daphnia* (National Library of Medicine (US), National Center for Biotechnology Information) 98
- [2] Smirnov N N 2017 *Physiology of the Cladocera* (Amsterdam: Academic Press) 418
- [3] Dodson S L, Cáceres C E and Rogers D C 2010 *Cladocera and Other Branchiopoda Ecology and Classification of North American Freshwater Invertebrates* ed J H Thorp and A P Covich (Academic Press) 773–827
- [4] Bekker E I, Karabanov D P, Galimov Y R, Haag C R, Neretina T V and Kotov A A 2018 *PLoS ONE* **13** e0194045
- [5] Skipper A N, Murphy D W and Webster D R 2019 *Journal of Plankton Research* **41** 142–53
- [6] Ziarek J J, Nihongi A, Nagai T, Uttieri M and Strickler J R 2011 *Hydrobiologia* **661** 317–27
- [7] Verbitskii V B and Verbitskaya T I 2012 *Biology Bulletin* **39** 93–8
- [8] Willming M M, Qin G and Maul J D 2013 *Environmental Toxicology and Chemistry* **32** 2738–45
- [9] Uttieri M, Sandulli R, Spezie G and Zambianchi E 2014 From small to large scale: A review of the Swimming Behavior of Daphnia *Daphnia: Biology and Mathematics Perspectives* (New York: Nova Sciences Publishers Inc) 309–22

- [10] Dodson S and Ramcharan C 1991 *Journal of Plankton Research* **13** 1367-79
- [11] Bahrndorff S, Michaelsen T Y, Jensen A, Marcussen L F, Nielsen M E and Roslev P 2016 *Journal of Applied Toxicology* **36** 896–902
- [12] Nikitin O and Latypova V 2014 *International Multidisciplinary Scientific GeoConference Surveying Geology and Mining Ecology Management, SGEM* **2** 85–92
- [13] Bownik A 2017 *Science of The Total Environment* **601–602** 194-205
- [14] Nikitin O V, Petrova V M and Latypova V Z 2015 *Research Journal of Pharmaceutical, Biological and Chemical Sciences* **6** 1729–36
- [15] Garcia R, Moss F, Nihongi A, Strickler J R, Göller S, Erdmann U, Schimansky-Geier L and Sokolov I M 2007 *Mathematical Biosciences* **207** 165–88
- [16] Vollmer J, Vegh A G, Lange C and Eckhardt B *Physical Review E - Statistical, Nonlinear, and Soft Matter Physics* **73** 061924
- [17] Komin N, Erdmann U and Schimansky-Geier L 2004 *Fluctuation and Noise Letters* **4** L151–9
- [18] Kuefler D, Avgar T and Fryxell J M 2013 *Functional Ecology* **27** 323–8
- [19] Krasky D A and Takagi D 2018 *Journal of Statistical Mechanics: Theory and Experiment* **2018** 103201
- [20] Nikitin O 2014 *Advances in Environmental Biology* **8** 74–8
- [21] R Core Team 2017 *R: A Language and Environment for Statistical Computing* (Vienna, Austria: R Foundation for Statistical Computing)
- [22] Nepf H 2008 *1.061 Transport Processes in the Environment* (Massachusetts Institute of Technology: MIT OpenCourseWare)
- [23] Berg H C 1993 *Random Walks in Biology* (Princeton: Princeton University Press) 152
- [24] Larsson P and Kleiven O T 1996 Food search and swimming speed in *Daphnia Zooplankton: Sensory Ecology and Physiology* ed P H Lenz, D K Hartline, J E Purcell and D L Macmillan (Amsterdam: Gordon and Breach Science Publishers) 375–87
- [25] Nikitin O V, Nasyrova E I, Nuriakhmetova V R, Stepanova N Yu, Danilova N V and Latypova V Z 2018 *IOP Conference Series: Earth and Environmental Science* **107** 012068

Acknowledgement

We are grateful to Shamil Zaripov, of the Department of Ecological Systems Modeling (Institute of Environmental Sciences, Kazan Federal University) for stimulating discussions.

This work was supported by the research grant of Kazan Federal University.